

IT

Struttura a monoscocca in acciaio inox AISI 304; finitura esterna satinata scotch-brite; spessore di isolamento pari a 85mm per la scocca e 65mm per la porta, con schiumatura ad alta densità (40 kg/m3) senza HFC; piedini in acciaio inox regolabili h120/150mm; cella con angoli interni arrotondati per una perfetta pulizia ed igienicità; sbrinamento ed evaporazione dell'acqua di condensa a gas caldo; griglie GN 2/1 in rislán; cremagliere porta griglie in ABS amovibili, senza l'ausilio di utensili; flusso d'aria laterale; porte auto-chiudenti da 100°; unità refrigerante a monoblocco brevettata e tropicalizzata (in classe climatica 5); serratura di serie; alimentazione a 230V/50Hz monofase standard.

EN

Stainless steel AISI 304 monocoque structure; scotch-brite external satin finish; 85 mm high density HFC free polyurethane foam insulation (40kg/m3) for the body and 65mm thickness for the door; stainless steel adjustable feet h120/150; cell with rounded internal edges for a perfect cleaning and hygiene; hot gas defrosting and condensation water evaporation; GN 2/1 rislán grids; removable racks for ABS grids, no tools needed; lateral air flow; self-closing doors from 100°; patented and tropicalized monobloc refrigerating unit (climatic class 5); lock as standard; standard power supply 230V/50Hz monophase.

FR

Structure à caisse unique en acier inox AISI 304; finition extérieure satinée Scotch-brite; épaisseur d'isolation par injection de mousse polyuréthane à haute densité (40 kg/m3) sans HFC de 85mm pour la caisse et de 65 mm pour la porte; pieds réglables h120/150mm; chambre froide avec angles internes arrondis pour un nettoyage et une hygiène parfaits; dégivrage et évaporation de l'eau de condensation par gaz chaud; grilles GN 2/1 en Rislán; crémaillères amovibles sans outils pour grilles en ABS; flux d'air latéral; porte à fermeture automatique de 100°; unité frigorifique avec monobloc breveté et tropicalisé (classe climatique 5); serrure de série; alimentation standard 230V/50Hz une seule phase.

DE

Monocoque-Ausführung aus Edelstahl AISI 304 mit satinierten Außenflächen (Schoch-Brite); 85 mm starke Rahmen-Isolierung und 65 mm starke Tür-Isolierung aus hochverdichtetem Polyethanschaum (40kg/m3) ohne HFC; Stellfüße aus Edelstahl H 120/150; Kühlzelle mit abgerundeten Innenecken für eine einfache Reinigung und optimale Hygiene; automatische Kondenswasserverdunstung und Abtauung durch heißen Gas; Rislán Gitter GN 2/1; ABS-Stangen für Gitter, abnehmbar ohne den Einsatz von Werkzeugen; seitliche Belüftung; selbstschließende Tür ab 100°; patentiertes und tropikalisiertes Monoblockkälteaggregat (Klimatische Klasse 5); serienmäßiges Schloss; Standard Spannung 230V/50Hz einphasig.



ES

Estructura monocasco de acero inoxidable AISI 304; acabado exterior satinado scotch-brite; espesor de aislamiento 85 mm para el casco y 65 mm para la puerta con espuma de poliuretano de alta densidad (40 kg/m3) sin HFC; piés ajustable de acero inoxidable h120/150mm; cámara con equinas interiores redondeadas para un perfecta limpieza y higiene; deshielo y evaporación del agua de condensación "a gas caliente"; rejillas GN 2/1 de rislán; cremallera para rejillas de ABS extraíbles, sin el uso de herramientas; flujo de aria lateral; puertas con autocerrado con bloqueo a 100°; unidad refrigeradora monocasco patentada y tropicalizada (en clase climática 5); cerradura de serie; alimentación de 230V/50Hz monofásica estándar.

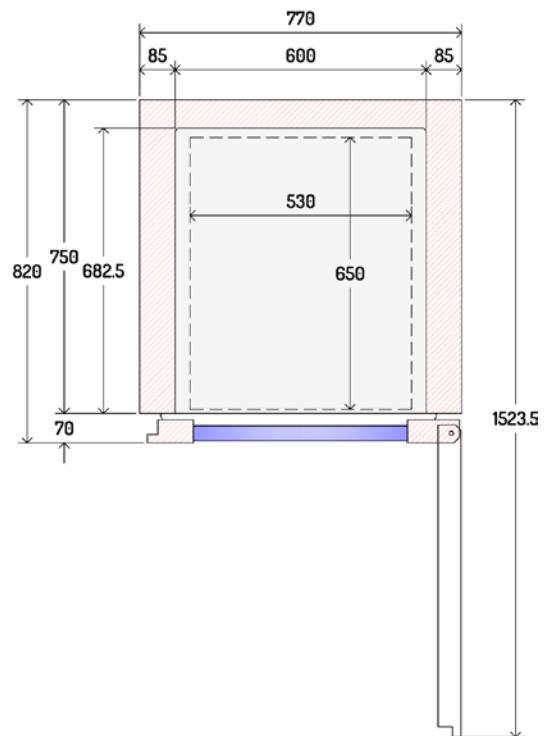
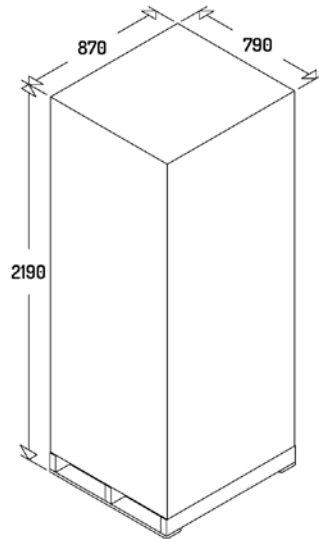
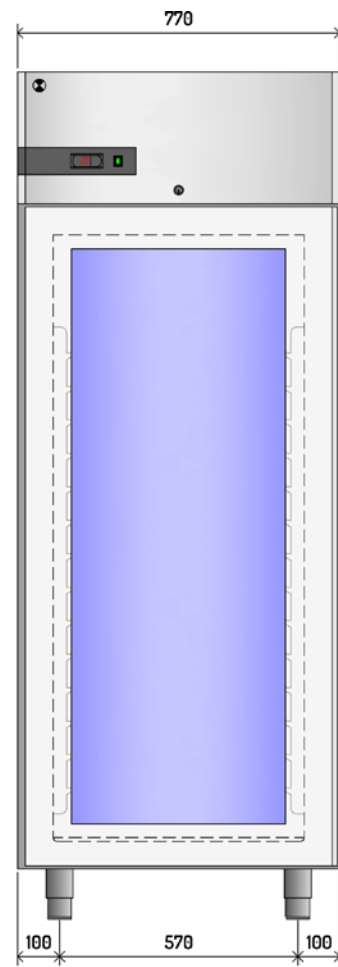
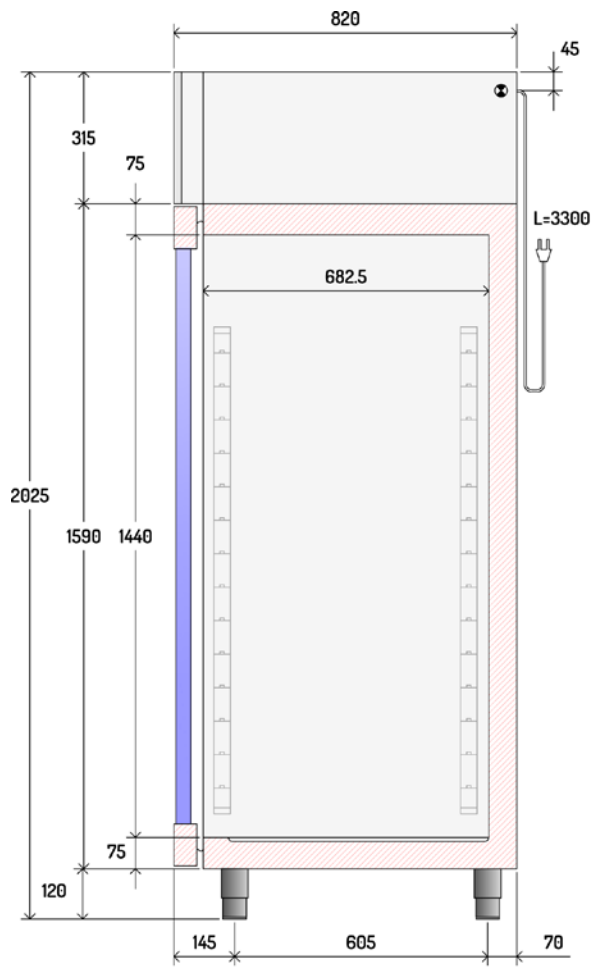

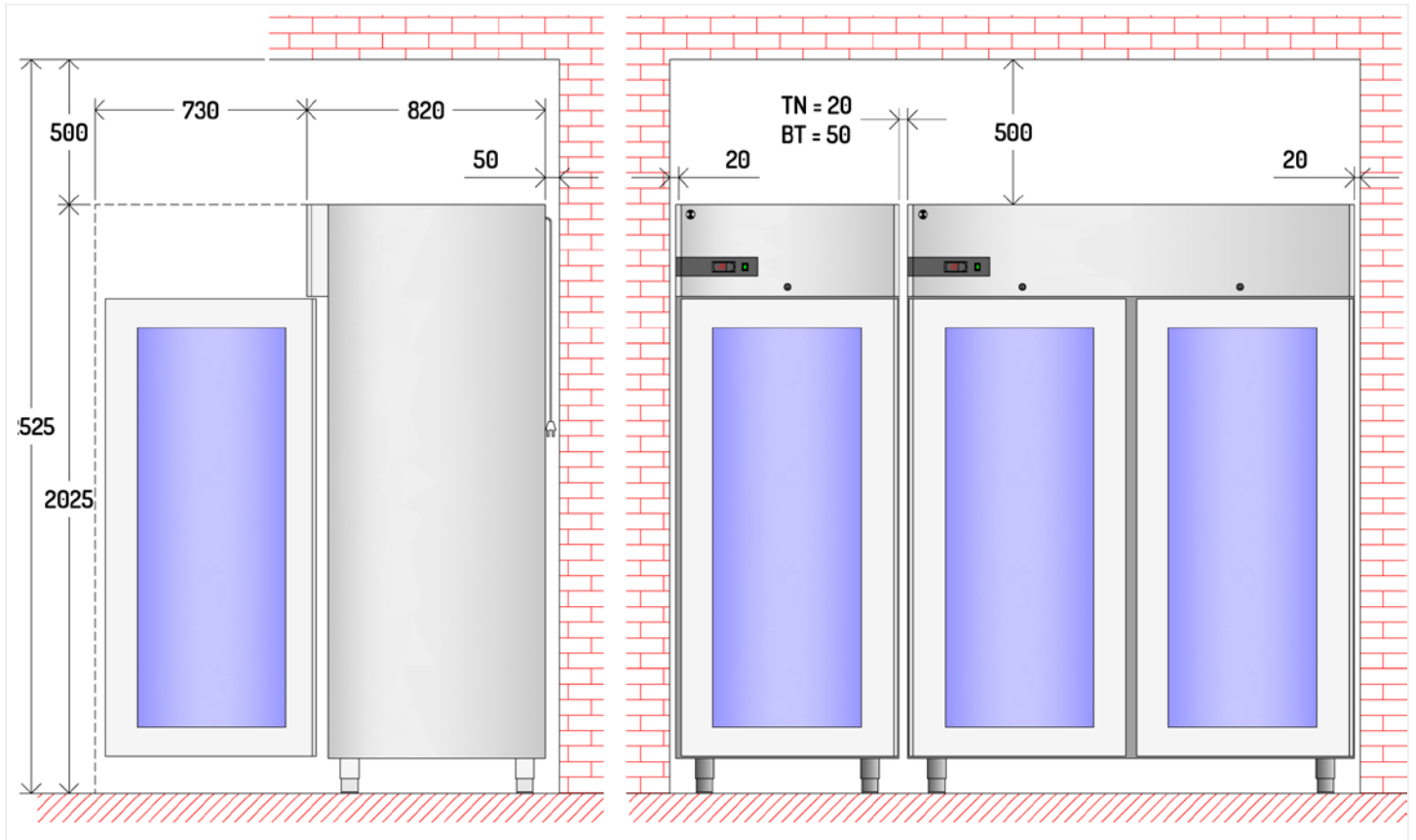



		700 TN PV	700 BT PV	
	Ricambio Minimo Aria Minimum Replacement Air	mc/h	290	410
	Calore Emesso Heat Output	watt	390	770
	Versione Remota Remote Version			
	Linea di Aspirazione Suction Line	mm	ø 8	ø 10
	Linea Liquido Liquid Line	mm	ø 6	ø 6
	Potenza Sbrinamento Elettrico Electric Defrost Power	watt	450	900

Modello - Model - Model - Gerätetyp	AN07V2500	AN07V2510
NEOS GN	D	E
Descrizione - Description - Description - Beschreibung	700 PV TN	700 PV BT
Range	0°C +10°C	-20°C -10°C
Funzionamento - Operating Mode - Mode de fonctionnement - Betriebsmodus S = Statico - Static - Statique - Stille Kühlung V = Ventilato - Ventilated - Ventilé - Umluftkühlung	V	V
Capacità lorda - Gross Capacity - Capacité brute - Bruttovolumen	600	600
Materiale Esterno - External Material - Matériau Extérieur - Verstoff Außen	304	304
Dimensioni esterne - External Dimension - Dimensions externes - ußenabmessungen		
Lunghezza - Width - Largeur - Breite	770	770
Profondità / con porte aperte - Depth / with open doors Profondeur avec portes ouverte - Tiefe / mit geöffneter Tü	820/1520	820/1520
Altezza - Height - Hauteur - Höhe	2025	2025
Materiale Interno - Internal Material - Matériau Intérieur - Verstoff Innen	304	304
Dimensioni interne - Internal Dimension - Dimensions internes - Innenabmessungen		
Lunghezza - Width - Largeur - Breite	600	600
Profondità - Depth - Profondeur - Tiefe	682,5	682,5
Altezza - Height - Hauteur - Höhe	1440	1440
Porte - Doors - Portes - Türen	1, Glass	1, Glass
Dotazione Standard - Standard Equipment - Equipement standard - Standardausstattung	Griglia plastificata - Plastic-Coated Grid Grille Plastifiée - Kunststoff-Beschichtetes Gitter 530x650	
	3	3
Luce interna - Internal light - Eclairage intérieure - Innerbeleuchtung	●	●
Serratura - Lock - Serrure - Schloss	●	●
Sbrinamento - Defrost - Dégivrages - Abtauen		
Type	Hot Gas	Hot Gas
N° Defrost in 24 hrs.	3	6
Evaporazione acqua sbrinamento - Evaporation of defrost water Evaporation eau de dégivrage - Tauwasserverdunstung	Automatic by Hot Gas	Automatic by Hot Gas
Compressor embraco		
Model	EMT6165U	NEU2168U
Potenza - Power - Puissance - Leistung	1/3	3/4
T° Evaporation	-10	-30
Potenza frigorifera - Refrigerant Power - Puissance frigorifique - Kälteleistung	520	600
Refrigerante - Refrigerant type - Réfrigérant type - Kältemitteltyp	R290 / 3	R290 / 3
Quantità di refrigerante - Refrigerant quantity - Quantité de réfrigérant - Kältemittelmenge	90	120
Potenza assorbita - Total Power - Puissance - Leistung	330W 2,1A / 350W 2,3A	650W - 3,2 A / 840W - 4 A
Tensione alimentazione - Supply Voltage - Tension d'alimentation - Anschlussspannung	230V~ 50Hz	230V~ 50Hz
Noise Level	49	61
Peso Netto - Net weight - Poids net - Netto Gewicht	150	150
Versione Predisposta - Remote version - Version sans groupe - Modelle ohne Aggregat Sbrinamento elettrico - Electrical defrosting - Dégivrage électrique - Elektrische Abtaung	---	---
Efficienza Energetica - Energy Efficiency - Classe Énergie - Energieeffizienzklasse	D	E
Energia - Energy - Énergie - Energie	831	3090
Volume Netto - Net Volume - Volume Net - Nettoinhalt	472	472
Classe Climatica - Climate Class - Classe Climatique - Klima Klasse	4 30°C-55%	4 30°C-55%

● = Dotazione di serie - Standard equipment - Dotation standard - Serien Ausstattung □ = Optional