

**IT**

Modelli cilindrici da 100 o 150 litri con riscaldamento diretto o indiretto. Vasca di cottura con fondo in AISI 316. Struttura portante in acciaio inox e rivestimenti esterni in acciaio inox con finiture Scotch Brite. Coperchio normale o con autoclave. Immissione acqua in vasca tramite rubinetto (acqua calda/fredda) e canna di erogazione orientabile. Blocco del riscaldamento per sovratemperatura con termostato di sicurezza a riarmo manuale.

**EN**

100 or 150L cylindrical models with direct or indirect heating. Cooking bath with AISI 316 bottom; stainless steel frame and Scotch Brite external panels. Normal or autoclave cover, water faucet (hot/cold water) with adjustable high spout. Heating block for over-temperature with manual reset safety thermostat.

**FR**

Modèles cylindriques de 100 ou 150 lt avec chauffe directe ou indirecte. Cuve de cuisson avec fond en AISI 316. Structure portante en acier inox et revêtements externes en Scotch Brite. Couverture normale ou autoclave. Introduction d'eau dans la cuve par robinet (eau chaude/froide) et bec de distribution orientable. Blocage chauffe en cas de surchauffe avec thermostat de sécurité à réarmement manuel.

**DE**

Zylinderförmige Modelle zu 100 oder 150 Lt mit direkter oder indirekter Erwärmung. Kochwanne mit Boden AISI 316. Tragende Struktur aus Edelstahl mit äußerer Verkleidung aus Scotch Brite. Normaler Deckel oder Dampfdruckdeckel. Wassereinfluss in Wanne durch Hahn (Warm-, und Kaltwasser) und orientierbares Auslaufrohr. Heizungseinheit für hohe Temperaturen und Sicherheitsthermostat mit manueller Rückstellung.



### PNG92MA0

### PNG92MB0

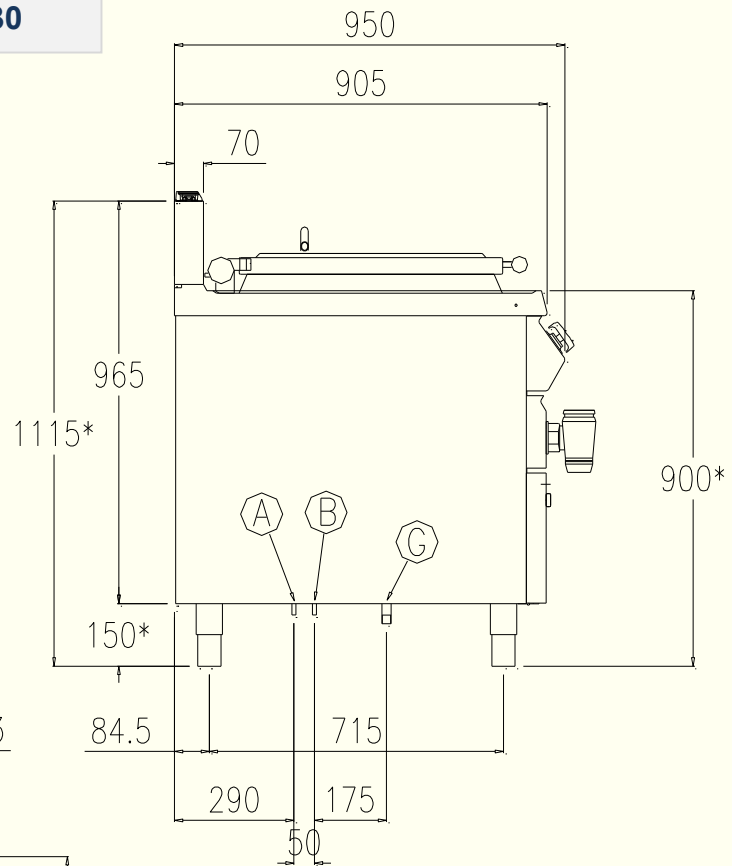
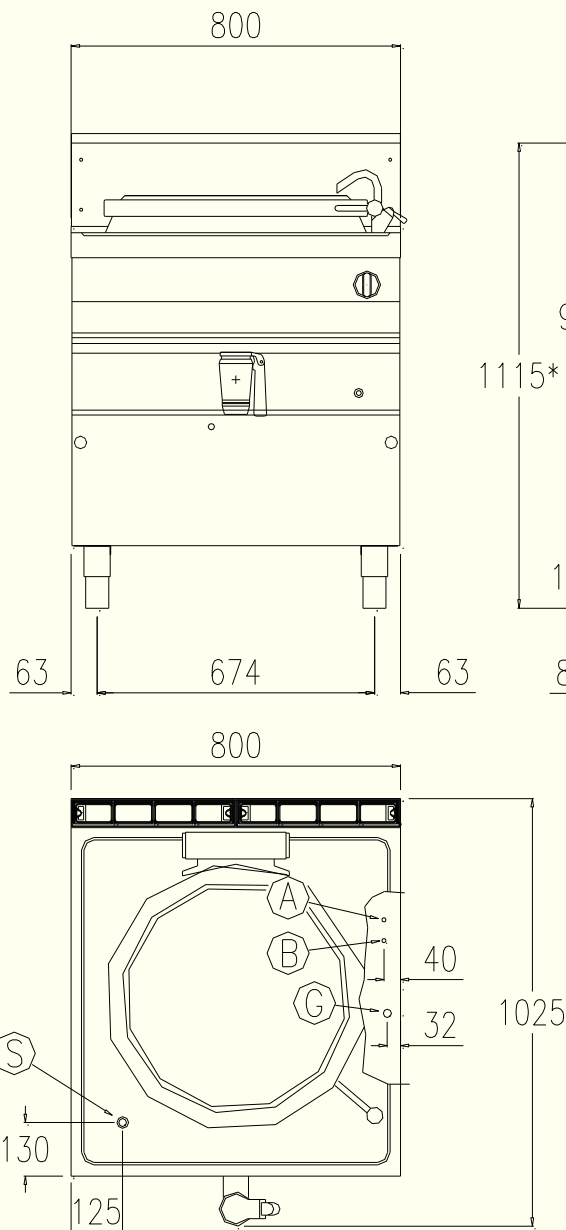

\* REG. +30 ; -30 mm

#### G 1/2"

Attacco Gas (secondo ISO 7-1) Gasanschluss (ISO 7-1)  
Gas Connection (ISO 7-1) Raccordement Gaz (ISO 7-1)

#### A Ø 10

Allacciamento Acqua Calda Warmwasseranschluss  
Hot water inlet Raccordement eau chaude

#### B Ø 10

Allacciamento Acqua Fredda Kaltwasseranschluss  
Cold water inlet Raccordement eau froide

**PNG92MC0**

**PNG92MD0**

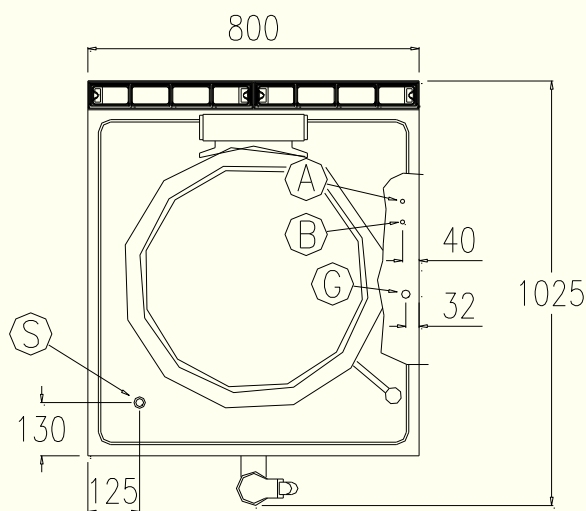
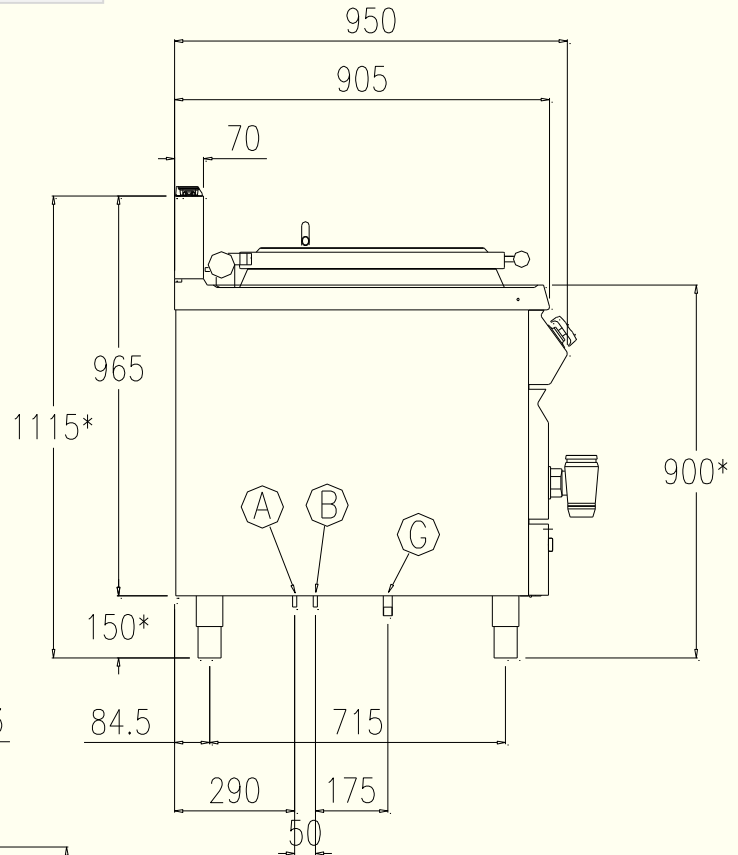
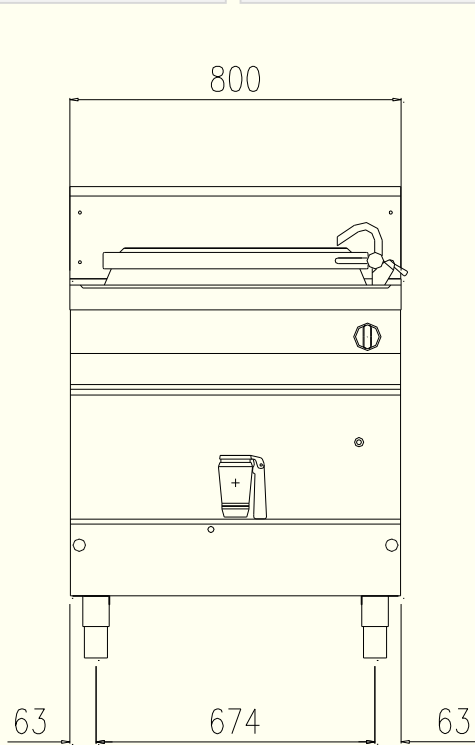

\* REG. +30 ; -30 mm

**G 1/2"**

Attacco Gas (secondo ISO 7-1) Gasanschluss (ISO 7-1)  
Gas Connection (ISO 7-1) Raccordement Gaz (ISO 7-1)

**A Ø 10**

Allacciamento Acqua Calda Warmwasseranschluss  
Hot water inlet Raccordement eau chaude

**B Ø 10**

Allacciamento Acqua Fredda Kaltwasseranschluss  
Cold water inlet Raccordement eau froide

<b>Modello - Model - Model - Gerätetyp</b>		PNG92MA0	PNG92MB0	PNG92MC0	PNG92MD0
	<b>Dimensioni esterne - External Dimension</b> Dimensions externes - ußenabmessungen				
	<b>Lunghezza - Width - Largeur - Breite</b>	mm	800		
	<b>Profondità - Depth - Profondeur - Tiefe</b>	mm	900		
	<b>Altezza - Height - Hauteur - Höhe</b>	mm	900		
	<b>Numero di vasche - Number of wells</b> Nombre de réservoirs - Anzahl der Tanks	1			
	<b>Capacità vasca - Well capacity</b> Capacité du réservoir - Tankinhalt	lt	100	150	
	<b>Dimensioni utilizzabili vasca - Usable well dimension</b> Utilisable dimension bien - Backenabmessung Dimension	mm	ø600 x h=415	ø600 x h=540	
	<b>Riscaldamento - Heating</b> Chauffe - Erwärmung	°C	diretto - direct - direct - direkter		
	<b>Attacco rete gas - Gas connector</b> Liaison réseau gaz - Gasanschluss	ø 1/2" ISO R7			
	<b>Collegamento acqua - Water connection</b> Wasseranschluss - Connexion eau	ø10 mm			
	<b>Pressione autoclave - Autoclave pressure</b> Autoklavdruck - Pression interstice	bar	---	0,05	---
	<b>Gas Version - Gas Version</b>				
	<b>Potenza - Power - Puissance - Macht</b>	kW	21		
	<b>Gas Consumption</b>				
	G20	mc/h	2,222		
	G30	kg/h	1,656		
	G31	kg/h	1,631		
	<b>Peso netto - Net weight - Poids net - Nettogewicht</b>	kg	130	140	140
	<b>Volume - Volume - Volume - Volumen</b>	mc	1,1	1,1	1,1

## ACCESSORI - ACCESSORIES - ACCESSOIRES - ZUBEHÖRE

<b>Cestelli - Baskets - Paniers - Korbe</b>		<b>KPN0010 - ø560x350</b>	<b>KPN0020 - ø560x440</b>
<b>Cestelli - Baskets - Paniers - Korbe</b>		<b>KPN0030 - ø560x350</b>	<b>KPN0040 - ø560x440</b>
<b>Cestelli - Baskets - Paniers - Korbe</b>		<b>KPN0050 - ø560x350</b>	<b>KPN0060 - ø560x440</b>

PNG92MF0

PNG92MG0

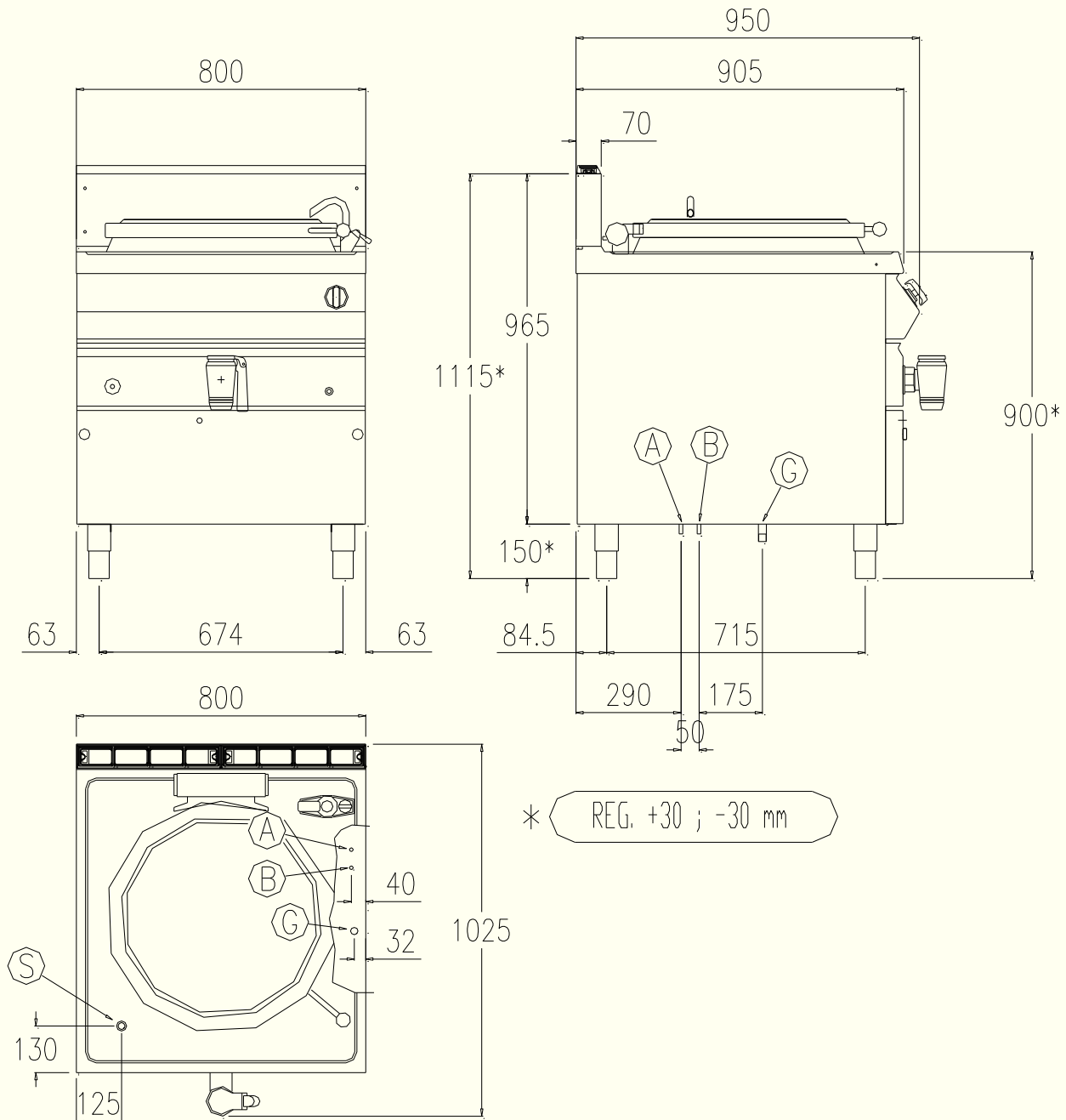

### G 1/2"

Attacco Gas (secondo ISO 7-1) Gasanschluss (ISO 7-1)  
Gas Connection (ISO 7-1) Raccordement Gaz (ISO 7-1)

### A Ø 10

Allacciamento Acqua Calda Warmwasseranschluss  
Hot water inlet Raccordement eau chaude

### B Ø 10

Allacciamento Acqua Fredda Kaltwasseranschluss  
Cold water inlet Raccordement eau froide

### PNG92MH0

### PNG92MI0

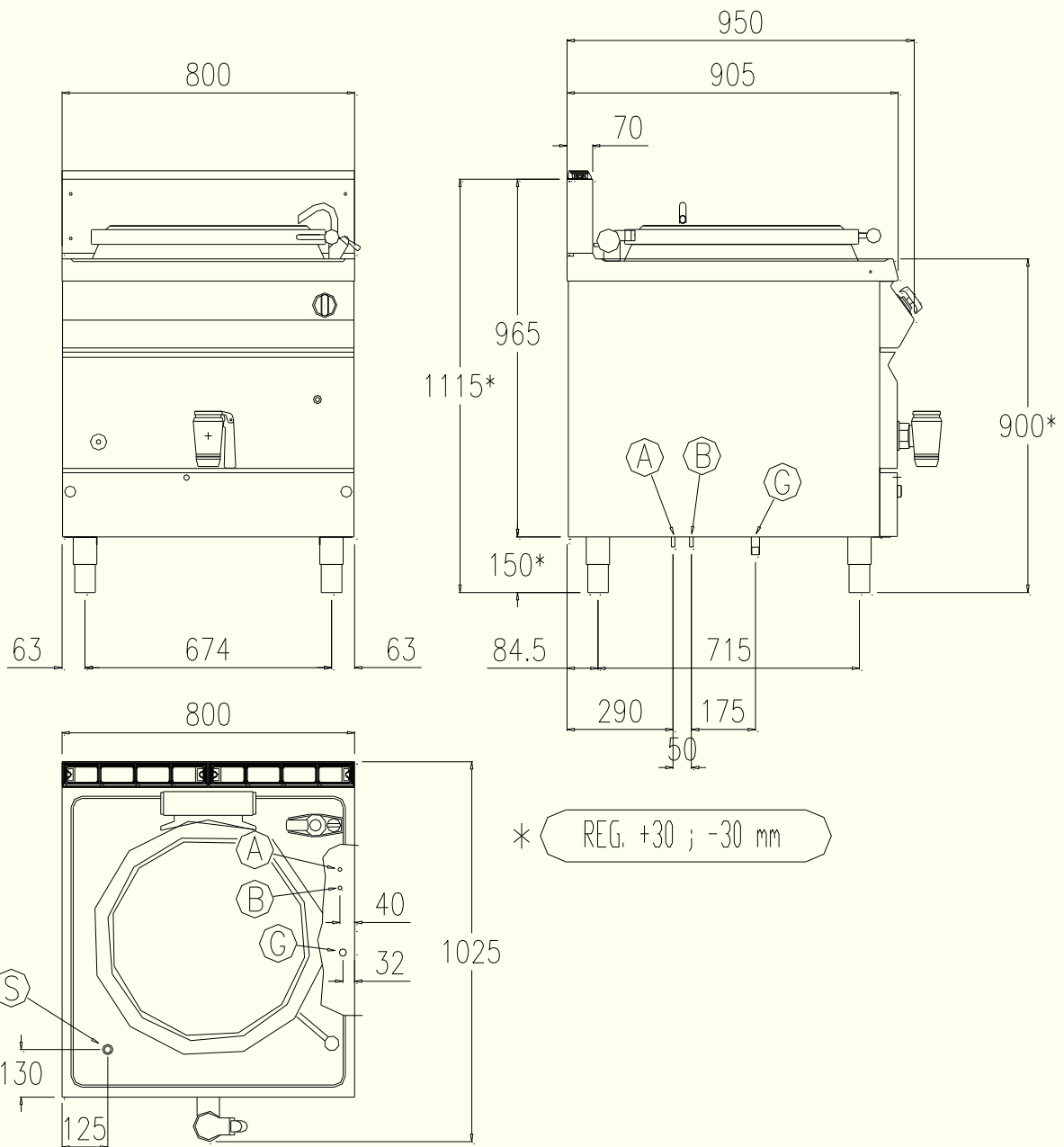

#### G 1/2"

Attacco Gas (secondo ISO 7-1) Gasanschluss (ISO 7-1)  
Gas Connection (ISO 7-1) Raccordement Gaz (ISO 7-1)

#### A Ø 10

Allacciamento Acqua Calda Warmwasseranschluss  
Hot water inlet Raccordement eau chaude

#### B Ø 10

Allacciamento Acqua Fredda Kaltwasseranschluss  
Cold water inlet Raccordement eau froide

<b>Modello</b> - Model - Model - Gerätetyp		PNG92ME0	PNG92MF0	PNG92MG0	PNG92MH0	
	<b>Dimensioni esterne</b> - External Dimension Dimensions externes - ußenabmessungen					
	<b>Lunghezza</b> - Width - Largeur - Breite	mm	800			
	<b>Profondità</b> - Depth - Profondeur - Tiefe	mm	900			
	<b>Altezza</b> - Height - Hauteur - Höhe	mm	900			
	<b>Numero di vasche</b> - Number of wells Nombre de réservoirs - Anzahl der Tanks	1				
	<b>Capacità vasca</b> - Well capacity Capacité du réservoir - Tankinhalt	lt	100	150		
	<b>Dimensioni utilizzabili vasca</b> - Usable well dimension Utilisable dimension bien - Backenabmessung Dimension	mm	ø600 x h=415	ø600 x h=540		
	<b>Riscaldamento</b> - Heating Chauffe - Erwärmung	°C	indiretto - indirect - indirect - indirekter			
	<b>Attacco rete gas</b> - Gas connector Liaison réseau gaz - Gasanschluss	ø 1/2" ISO R7				
	<b>Collegamento acqua</b> - Water connection Wasseranschluss - Connexion eau	ø10 mm				
	<b>Pressione autoclave</b> - Autoclave pressure Autoklavdruck - Pression interstice	bar	---	0,05	---	0,05
	<b>Gas Version</b> - Gas Version					
	<b>Potenza</b> - Power - Puissance - Macht	kW	21			
	<b>Gas Consumption</b>					
	G20	mc/h	2,222			
	G30	kg/h	1,656			
	G31	kg/h	1,631			
	<b>Peso netto</b> - Net weight - Poids net - Nettogewicht	kg	170	180	180	190
	<b>Volume</b> - Volume - Volume - Volumen	mc	1,1	1,1	1,1	1,1

## ACCESSORI - ACCESSORIES - ACCESSOIRES - ZUBEHÖRE

<b>Cestelli</b> - Baskets - Paniers - Korbe		<b>KPN0010</b> - ø560x350	<b>KPN0020</b> - ø560x440
<b>Cestelli</b> - Baskets - Paniers - Korbe		<b>KPN0030</b> - ø560x350	<b>KPN0040</b> - ø560x440
<b>Cestelli</b> - Baskets - Paniers - Korbe		<b>KPN0050</b> - ø560x350	<b>KPN0060</b> - ø560x440